

ONE YEAR LIMITED WARRANTY

(Valid in USA only)

HoMedics, Inc., guarantees this product free from defects in material and workmanship for a period of one year from the date of purchase, except as noted below.

This HoMedics product warranty does not cover damage caused by misuse or abuse; accident; the attachment of any unauthorized accessory; alteration to the product; or any other conditions whatsoever that are beyond the control of HoMedics. This warranty is effective only if the product is purchased and operated in the USA. A product that requires modification or adaptation to enable it to operate in any country other than the country for which it was designed, manufactured, approved and/or authorized, or repair of products damaged by these modifications is not covered under warranty. HoMedics shall not be responsible for any type of incidental, consequential or special damages. All implied warranties, including but not limited to those implied warranties of fitness and merchantability, are limited in the total duration of one year from the original purchase date.

To obtain warranty service on your HoMedics product, either hand deliver or mail the unit and your dated sales receipt (as proof of purchase), postpaid, along with check or money order in the amount of \$5.00 payable to HoMedics, Inc. to cover handling.

Upon receipt, HoMedics will repair or replace, as appropriate, your product and return it to you, postpaid. If it is appropriate to replace your product, HoMedics will replace the product with the same product or a comparable product at HoMedics' option. Warranty is solely through HoMedics Service Center. Service of this product by anyone other than HoMedics Service Center voids warranty.

This warranty provides you with specific legal rights. You may have additional rights which may vary from state to state. Because of individual state regulations, some of the above limitations and exclusions may not apply to you.

For more information regarding our product line in the USA, please visit: www.homedics.com

Mail To:

HoMedics
Consumer Relations
Service Center Dept. 168
3000 Pontiac Trail
Commerce Township, MI
48390

e-mail:
cservice@homedics.com

phone:
800-466-3342

ILLUMINATED TABLETOP RELAXATION FOUNTAIN

enviraScape SLATE FALLS



**Instruction Manual and
Warranty Information**

WFL-SLFA

1 year
limited warranty

The soothing sounds of nature

Thank you for purchasing EnviraScape, HoMedics' tabletop relaxation fountain. This, like the entire HoMedics product line, is built with high-quality craftsmanship to provide you years of dependable service. We hope that you will find it to be the finest product of its kind.

EnviraScape enables you to create an all-encompassing environment with sound. The sound of flowing water enhances your environment by releasing negative ions, and promoting relaxation. Only EnviraScape offers you the luxury of these vital benefits with its creative design which adds beauty to any indoor environment.

EnviraScape Features

- Innovative, artistic design enhances the environment at home or at work.
- Special effect lighting illuminates fountain for a more dramatic effect.
- The soothing sound of cascading waters create a stress free ambiance.
- Improves concentration by masking distractions so you can stay focused.
- Durable electrical water pump can be operated from any indoor electrical outlet.
- Convenient tabletop size-fountain measures 7.5"L x 7.5"W x 14"H.

IMPORTANT SAFETY INSTRUCTIONS:

When using an electrical appliance, basic precautions should always be followed, including the following:

READ ALL INSTRUCTIONS BEFORE USING

DANGER - To reduce the risk of electric shock:

- Always unplug the appliance from the electrical outlet immediately after using and before cleaning.
- Do not reach for an appliance that has fallen into water. Unplug it immediately.
- Do not place or store appliance where it can fall or be pulled into a tub or sink. Do not place in or drop into water or other liquid.
- Do not connect to any voltage other than that shown on the pump.
- Do not pump flammable liquids.
- Do not use water above 86° Fahrenheit.

CAUTION:
The pump must be completely submerged in water. If the pump is making noises, most likely it is not completely submerged in water.

CAUTION:
Only set the fountain and fountain parts on waterproof surfaces

WARNING - To reduce the risk of burns, fire, electric shock or injury to persons:

- An appliance should never be left unattended when plugged in. Unplug from outlet when not in use and before putting on or taking off parts or attachments.
- Close supervision is necessary when this appliance is used by or near children, invalids or disabled persons.
- Use this appliance only for its intended use as described in this manual. Do not use attachments not recommended by HoMedics; specifically any attachments not provided with the unit.
- Never operate this appliance if it has a damaged cord, plug, pump, cable or housing. If it is not working properly, if it has been dropped or damaged, return it to Homedics Service Center for examination and repair.
- Keep cord away from heated surfaces.
- Never drop or insert any object into any opening.
- Do not operate where aerosol (spray) products are being used or where oxygen is being administered.
- Do not carry this appliance by power cord or use cord as handle.
- To disconnect, remove plug from outlet.
- This appliance is designed for indoor use only. Do not use outdoors.

SAVE THESE INSTRUCTIONS

Caution – Please read all instructions carefully before operating.

- Never leave the appliance unattended, especially if children are present.
- Never cover the appliance when it is in operation.
- This unit should not be used by children without adult supervision.
- Connect the pump with the proper voltage as indicated on the pump label.
- Always keep the cord away from high temperature and fire.
- Unplug the pump from power source before cleaning, maintenance or disassembling.
- To get the best flowing effect, product must be placed on a flat surface and should never be placed on an electrical appliance.
- Never let pump run dry, as this will shorten life of the pump.
- Do not lift, carry, hang, or pull the pump by the power cord.
- Operate with tap or distilled water.
- Operate pump completely submerged for proper cooling.
- The electrical cord of this product cannot be replaced. If it sustains damage, you must stop using this product immediately and return it to the HoMedics Service Center for repair. (See the warranty section for HoMedics address.)
- Disconnect the appliance from outlet before putting hands into water.

Assembly and Instructions for Use

1. Unpack the product. Wipe off dust with a damp cloth. (Fig 1)

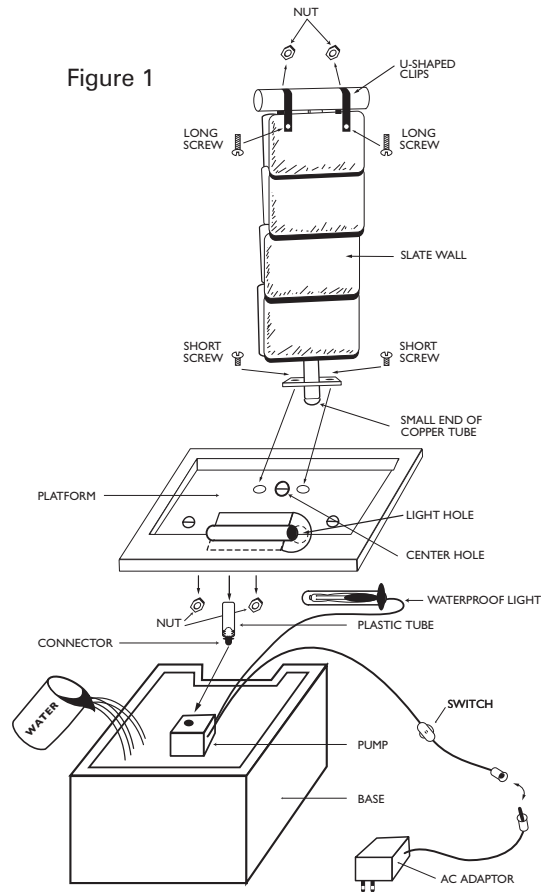

2. Familiarize yourself with the pump. The pump speed is controlled by the switch located at the front of the pump. The speed is indicated by a plus (+) and minus (-) sign. To increase the speed, move the switch slowly downward in the direction of the plus sign. You will hear a click as the switch moves to each speed level. At its highest speed level, the switch will cease to move any further. To decrease the pump speed, move the switch upward toward the minus sign. Similarly, at its lowest speed, the switch will cease to move any further (Fig 2).
 NOTE: It is recommended the pump be set at its highest speed during assembly and later adjusted to a lower setting if desired. Be sure to unplug the pump before adjusting the speed setting.

Attention:
 In order to get best results, please operate pump completely submerged. Keep the water level above the minimum water level ALL THE TIME.

Figure 2

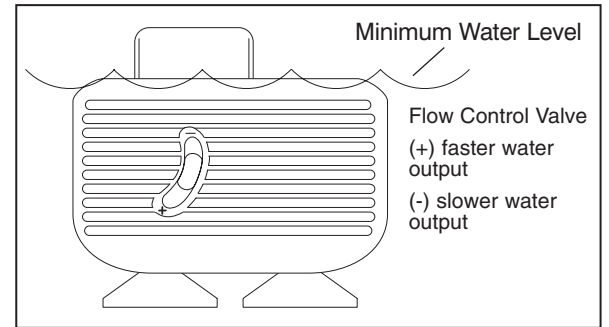

3. Insert the small end of the copper tube through the center hole of the platform and secure with the short screws and corresponding nuts. (Fig. 3)

Figure 3

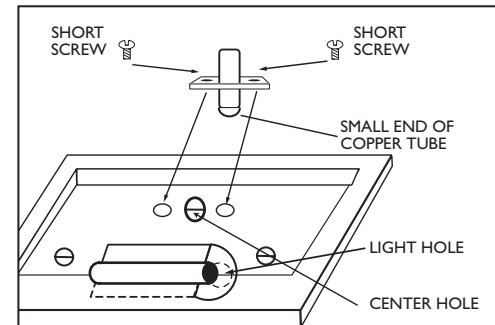

4. Insert the waterproof light into the light hole located under the platform. (Fig. 4) Be sure to push far enough so "rubber neck" is secure in the light hole. Slight twisting may help to push the rubber neck through the hole more easily. Note: Be gentle with the bulb cover since it is made of glass.

Figure 4

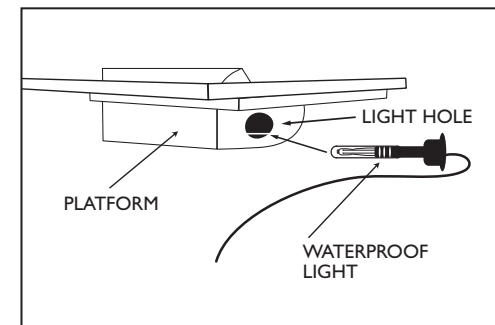

5. Insert the small end of the copper tube into the plastic tube (the end without the black connector). (Fig. 5)

Figure 5

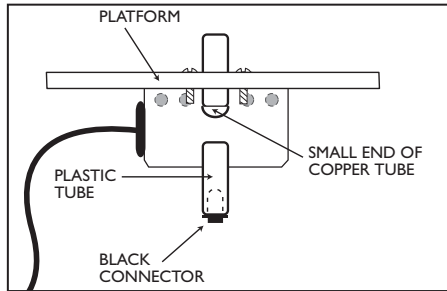

6. Insert the end of the plastic tube with the black connector into the pump. (Fig. 6)

Figure 6

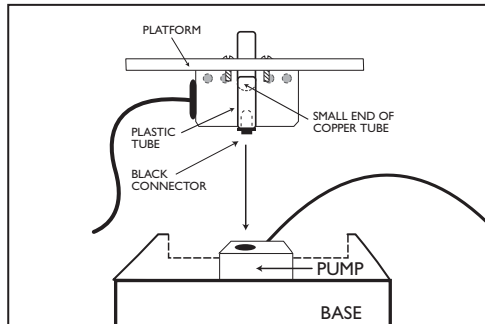

7. Then place the platform on the base so it sits level. Lead the cord out through the cord slot located on the upper backside of the base. (Fig. 7.)
8. Slide the U-shaped clips over the copper bar, one on either side of the vertical pole. (Fig. 8)

Figure 7

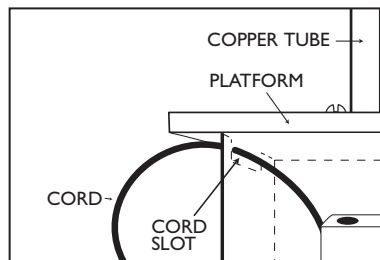
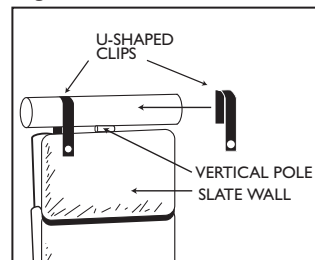
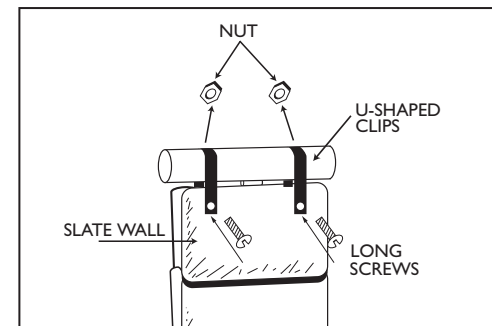

Figure 8



9. Hold the slate wall in between the U-shaped clips, aligning the holes. Then, slide the long screws through the holes. Secure with the corresponding nuts on the back. (Fig. 9)

Figure 9



10. Fill the base with clean water until the water level is 3/4" below the lowest edge of the base. (Fig. 10)

11. Attach the A/C adaptor jack to the base power cord. (Fig. 1)

Figure 10

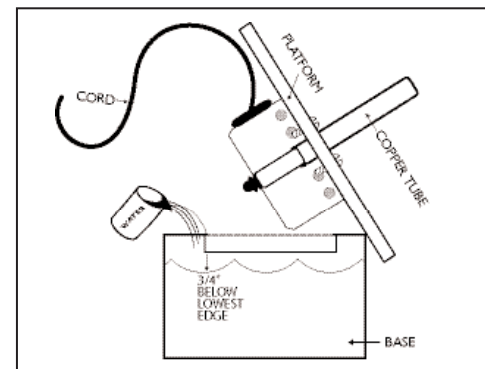

12. Plug the cord into 120V household outlet. The fountain is controlled by a switch located on the power cord. If pump does not operate, rotate in-line switch once to turn "on" and once to turn "off".
Note: Ensure that the electrical cord loops below the electrical outlet to form a "Drip Loop". This will prevent water from running down the electrical cord into the electrical outlet. (Fig. 11)

Maintenance

- **To clean the pump:**

Unplug from electrical outlet. Remove it from the base of the fountain. Use a small brush or stream of water to remove any debris (Fig 12).

- **To keep water clean:**

Periodically change water and clean the product according to the water condition. Keeping the water clean prevents the water from becoming sticky and forming micro-organisms. We recommend distilled water to prevent mineral build-up.

- **To clean off hard water deposits on the base:**

Soak the container in a mixture of vinegar and water to clean and remove any mineral build-up.

- **Keeping the water at an optimum level:**

Add water periodically to keep water level at an optimum level to avoid shortening the life of the pump.

NOTE: Never let the pump run dry, as this will shorten the life of the pump.

- **Fountain storage**

Unplug the fountain from the electrical outlet, empty the water, and store rocks and fountain in a dry, cool place.

- **Changing the light bulb**

First unplug fountain and let bulb cool down. Remove the bulb cover by holding glass bulb cover in dry hand and rubber neck with other hand. Slowly pull apart. Slight twisting may help to loosen. Be gentle with bulb cover since it is glass. Never pull on cord. Next pull bulb straight out and replace with new bulb, inserting prongs into the holes. Replace bulb cover securely.

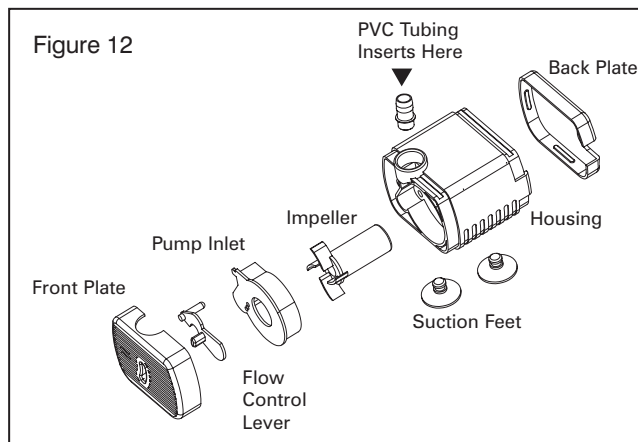

Caution:
All servicing of this fountain must be performed by authorized HoMedics service personnel only.

Troubleshooting

- **If the pump fails to operate, check the following:**

Check the circuit breaker, or try a different outlet to make sure the pump is getting electrical power.

NOTE: Always disconnect from electrical outlet before handling the pump.

- **If the pump gurgles, spews, or “burps”:**

Check the water level to make sure the pump has enough water to function.

- **Obtaining a desired water level:**

Check the water level daily the first week to measure the rate of evaporation; refill with water as needed.

- **If water is splashing outside the fountain:**

Adjust the flow control valve to a lower setting on the pump.

Figure 11

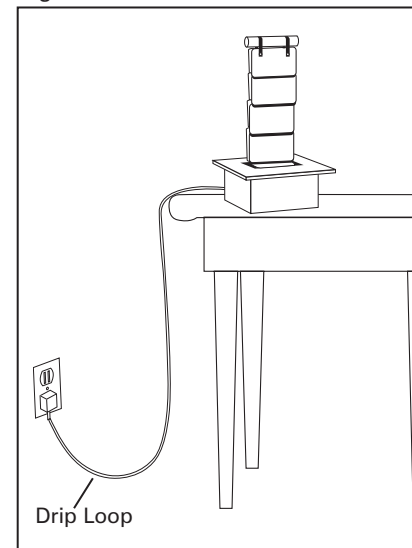

ILLUMINATED TABLETOP RELAXATION FOUNTAIN

enviraScape

Replacement Parts Order Form

PART	DESCRIPTION	QUANTITY	COST
PP-ROCKBLB	Replacement bulbs and covers for WFL-SLFA - pack of 5		\$5.00
SUBTOTAL			_____
TAX-Michigan Residents add 6%			_____
Total			_____

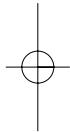

HOMEDICS®



Mail To:

HoMedics
Consumer Relations
Service Center Dept. 168
3000 Pontiac Trail
Commerce Township, MI
48390

e-mail:
cservice@homedics.com

Detach and return order form with check or money order payable to HoMedics, Inc.
Please allow 2 to 4 weeks for delivery.

Name

Address

City State Zip Code () Phone Number